

Bryan "Flexible Water Tube"
EB Series
Steam & Water Boilers

3,200,000 to 10,000,000 BTUH
Forced draft gas, oil or dual fuel fired



Steam Boiler
EB-75-S150-FDG



Water Boiler
EB-200-W-FDGO

 **BRYAN® BOILERS**

Originators of the "Flexible Water Tube" design





Low initial cost, reliable operating efficiency deliver substantial return on investment

- True “flexible water tube” design
- High quality steam for heat or process
- Pressurized firing for maximum performance

Quality Construction Features:

A. Water side or steam side interior accessible for cleanout and inspection, front and rear openings, upper and lower drums.

B. Large volume water leg downcomers promote rapid internal circulation, temperature equalization and efficient heat transfer.

C. Boiler tube and furnace area access panels: heavy gauge steel casing with 2” high temperature ceramic fiber and insulation, bolted and tightly sealed to boiler frame.

D. Flame observation port at rear of boiler.

E. Single side access; combustion chamber, tubes and burner head are completely accessible from one side simplifying maintenance and minimizing floor space.

F. Minimum sized flue vent.

G. Control panel: all controls installed with connections to terminal strip.

H. Forced draft, flame retention head type burner. Efficient combustion of oil or gas, plus quiet operation.

I. Heavy steel boiler frame, built and stamped in accordance with the appropriate ASME Boiler Code.

J. Heavy gauge steel boiler jacket with rust-resistant zinc coating and enamel finish, insulated with 1½” fiberglass to ensure exceptionally cool outer surface.

K. Bryan bent water tubes are flexible, individually replaceable without welding or rolling. Never more than two tube configurations.

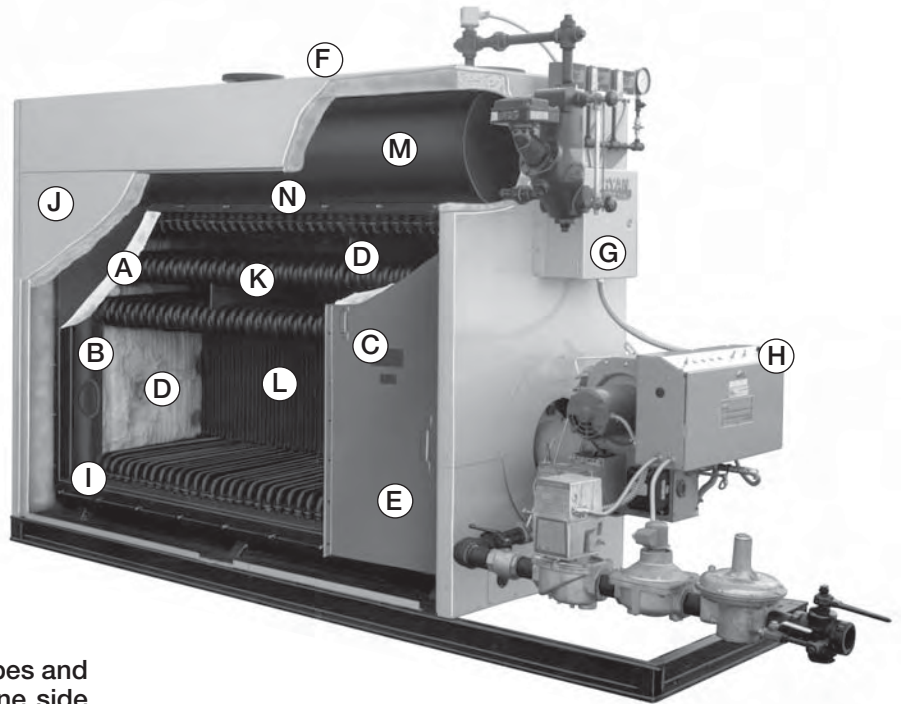

L. Internal water-cooled furnace with low heat release rate.

M. Steam boilers with extra large drum with high steam release area ensure stable water level and dry steam.

N. Pressurized design: inner fireside casing constructed of heavy gauge steel, completely seal-welded, lined with high temperature insulation and refractory.

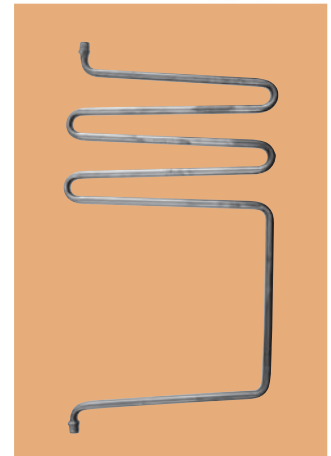

Bryan EB Series Boiler Specifications

BOILER MODEL	INPUT MBH (KW)	NOMINAL OUTPUT		STEAM OUTPUT LBS./HR** (KG)	APPROX. SHIP WT. LBS. (KG)
		MBH (KW)*	BHP*		
EB-75	3,200 (938)	2,560 (750)	75	2,639 (1,197)	5,810 (2,635)
EB-100	4,200 (1,230)	3,360 (984)	100	3,463 (1,570)	7,110 (3,225)
EB-125	5,250 (1,538)	4,200 (1,230)	125	4,329 (1,963)	8,300 (3,765)
EB-150	6,300 (1,845)	5,040 (1,476)	150	5,195 (2,356)	8,420 (3,819)
EB-175	7,325 (2,146)	5,860 (1,717)	175	6,041 (2,740)	11,175 (5,069)
EB-200	8,500 (2,490)	6,800 (1,992)	200	7,010 (3,179)	11,305 (5,128)
EB-240	10,000 (2,930)	8,000 (2,344)	240	8,247 (3,740)	14,455 (6,557)

NOTES: * Nominal output based on boiler industry standard of 80% of input. Actual combustion efficiencies will be fuel dependent.
 ** Lbs. steam per hour from and at 212° F.

Efficient “Flexible Water Tube” design assures easy maintenance and low cost operation

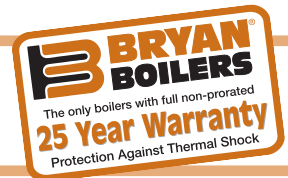

All Bryan EB Series boilers offer these operating and performance features

The Bryan Flexible Tube

Bryan’s exclusive “Flexible Tube” design eliminates the possibility of damage from so-called “thermal shock.” Tubes are easily removable and replaceable, without welding or rolling, eliminating long, expensive downtime should repairs ever be required.

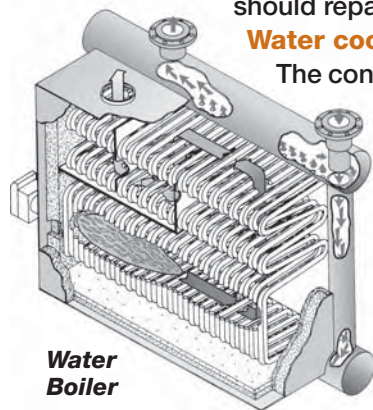

Water cooled furnace

The configuration of the water tubes provides a water cooled combustion chamber. A high percentage of the heating surface is exposed to direct radiant heat, increasing water velocities and heat transfer.

Large steam drum

The steam drum has generous water volume and steam release area. This

design, along with effective drum internal functions, results in a stable water level and produces extremely dry steam at all load conditions.

Accessibility of furnace and tube area

One hinged inner panel provides easy and complete access to furnace and boiler tube area, as well as to burner head. Other tube side panels are also removable, and all panels are heavily insulated and sealed to boiler frame. All access is from only one side.

Compact design, minimum floor space

With our compact water tube design, the overall size of the unit is less than most other types of boilers. Needing only 32" for tube removal, and on only one side of the boiler, the EB Series boiler occupies very little space in the boiler room. This can result in considerable savings in building costs. Pressurized firing permits minimum sized breaching and vent.

Multi-pass flue gas travel

High velocity four-pass flue gas travel is obtained by a unique baffling system. This contributes to maximum fire side heat transfer and overall boiler efficiency.

Thermal blend water return

Bryan’s unique “thermal blend” return blends cold or cooler return water with warmer boiler water blending it to design operating temperatures. An injector tube directs the “mixed” water flow through the downcomer to the lower header and heating surfaces at a temperature above possible condensing conditions. This reduces the possibility of “cold spots” and damage from corrosive condensation.

Positive internal circulation

Each pass of the Bryan water tube slopes upward. This configuration, along with the large volume down-comer water legs, provides the extremely rapid natural thermal internal circulation, promoting both high efficiency of heat transfer and uniform temperature throughout the boiler. Eliminating stress damage caused by unequal temperature distribution is especially important for heating systems, particularly where intermittent or continuous low temperature water returns may be encountered.

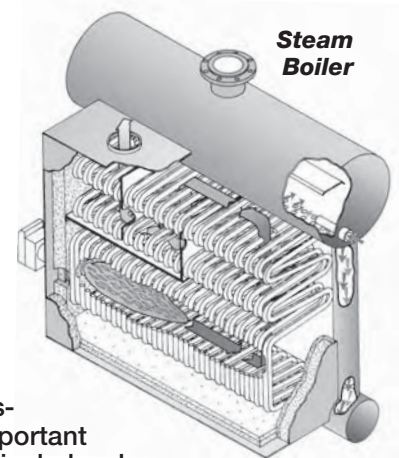

Bryan EB Series Boilers Standard and Optional Equipment

STANDARD EQUIPMENT FURNISHED

Water Boiler

Combination thermometer and altitude gauge, ASME Code rated boiler relief valve, water temperature control (240°F max std.), high limit control, probe LWCO.

Steam Boiler

Combination low water cutoff and pump control, auxiliary low water cutoff, high limit pressure control, ASME-rated safety valve, water glass set.

Straight gas fired unit

Electronic combustion safety control, automatic operating gas valve, safety gas valve, pilot solenoid valve, pilot ignition assembly, main manual gas shut-off valve, pilot cock, pilot and main gas pressure regulators, air safety switch, control panel, all controls installed and wired.

Straight oil fired unit

Electronic combustion safety control, oil valve, oil ignition transformer, two-stage fuel unit — spark ignition (EB75 & 100)/gas pilot (EB 125-240), oil nozzle assembly, control panel, all controls installed and wired.

Combination gas-oil unit

Electronic combustion safety control, automatic motorized gas valve, safety gas valve, pilot solenoid valve, pilot ignition assembly, main manual gas shut-off valve, pilot cock, pilot and main gas pressure regulators, air safety switch, manual fuel selector switch, oil valve, gas pilot, two-stage fuel unit, oil nozzle assembly, control panel, all controls installed and wired.

OPTIONAL EQUIPMENT, EXTRA COST

1. Manual reset high limit control
2. Manual reset low water cutoff
3. Auxiliary low water cutoff (standard on steam boilers)
4. Combination low water cutoff and feeder
5. Alarm bells or horns
6. CSD-1, FM, GE-GAP or other insurance approved control systems
7. Indicating lights, as desired
8. Lead-lag systems for two or more boilers with or without outdoor reset control
9. Draft control system

When ordering, please specify:

1. Boiler size
2. Supply and return temperatures required
3. Boiler relief valve setting
4. Type of fuel: natural, LP, or other gas and/or No. 2 oil
5. If gas, type, BTU content, specific gravity and pressure available
6. Electric power voltage, phase and frequency
7. Optional extra equipment or construction
8. Special approvals required (UL, CSD-1, FM, or GE-GAP)
9. Altitude

Bryan EB Series Steam & Hot Water Boilers

DIMENSIONS in inches (cm)													
Boiler Model Number	A Length of Jacket	B Width Outside Jacket	C Height Over Jacket	D Overall Length	E Gas Train Connection	F Supply Nozzle		G Return Conn.	H Flue Size	I Flue Location	J Clearance for Servicing Burner	K Min. Tube Removal Clearance	L Floor to Flow Nozzle
						15 psi	150 psi						
EB-75-S	75½ (191.77)	55 (139.70)	100¼ (254.64)	108¼ (274.96)	2½ (6.35)	6 (15.25)	4 (10.16)	2 (5.08)	12 (30.48)	13¼ (33.68)	48 (121.92)	32 (81.28)	104¾ (266.1)
EB-100-S	98 (248.9)	55 (139.70)	100¼ (254.64)	130½ (331.4)	2 (5.08)	8 (20.32)	6 (15.24)	2 (5.08)	16 (40.64)	16 (40.64)	48 (121.92)	32 (81.28)	104¾ (266.1)
EB-125-S	111 (281.94)	55 (139.70)	100¼ (254.64)	143½ (364.49)	2½ (6.35)	8 (20.32)	6 (15.24)	2 (5.08)	16 (40.64)	18¾ (47.63)	48 (121.92)	32 (81.28)	104¾ (266.1)
EB-150-S	111 (281.94)	55 (139.70)	100¼ (254.64)	143½ (364.49)	2½ (6.35)	8 (20.32)	6 (15.24)	2 (5.08)	16 (40.64)	18¾ (47.63)	48 (121.92)	32 (81.28)	104¾ (266.1)
EB-175-S	152¾ (387.99)	55 (139.70)	100¼ (254.64)	185¼ (470.54)	2½ (6.35)	10 (25.40)	6 (15.25)	2 (5.08)	18 (45.72)	18¾ (47.63)	48 (121.92)	32 (81.28)	104¾ (266.1)
EB-200-S	152¾ (387.99)	55 (139.70)	100¼ (254.64)	185¼ (470.54)	2½ (6.35)	10 (25.40)	6 (15.25)	2 (5.08)	18 (45.72)	18¾ (47.63)	48 (121.92)	32 (81.28)	104¾ (266.1)
EB-240-S	197¾ (502.3)	55 (139.70)	100¼ (254.64)	237¼ (602.6)	2½ (6.35)	10 (25.40)	6 (15.25)	2 (5.08)	20 (50.6)	20¾ (52.7)	48 (121.92)	32 (81.28)	104¾ (266.1)

DIMENSIONS in inches (cm)												
Boiler Model Number	A Length of Jacket	B Width Outside Jacket	C Height Over Jacket	D Overall Length	E Gas Train Connection	F Supply Nozzle	G Return Nozzle	H Flue Size	I Flue Location	J Clearance for Servicing Burner	K Min. Tube Removal Clearance	L Floor to Flow Nozzle
EB-100-W	98 (248.9)	50 (127.00)	87½ (222.25)	130½ (331.4)	2 (5.08)	6 (15.25)	6 (15.25)	16 (40.64)	16 (40.64)	48 (121.92)	32 (81.28)	90 (228.60)
EB-125-W	111 (281.94)	50 (127.00)	87½ (222.25)	143½ (364.49)	2½ (6.35)	6 (15.25)	6 (15.25)	16 (40.64)	18¾ (47.63)	48 (121.92)	32 (81.28)	90 (228.60)
EB-150-W	111 (281.94)	50 (127.00)	87½ (222.25)	143½ (364.49)	2½ (6.35)	6 (15.25)	6 (15.25)	16 (40.64)	18¾ (47.63)	48 (121.92)	32 (81.28)	90 (228.60)
EB-175-W	152¾ (387.99)	50 (127.00)	87½ (222.25)	185¼ (470.54)	2½ (6.35)	6 (15.25)	6 (15.25)	18 (45.72)	18¾ (47.63)	48 (121.92)	32 (81.28)	90 (228.60)
EB-200-W	152¾ (387.99)	50 (127.00)	87½ (222.25)	185¼ (470.54)	2½ (6.35)	6 (15.25)	6 (15.25)	18 (45.72)	18¾ (47.63)	48 (121.92)	32 (81.28)	90 (228.60)
EB-240-W	197¾ (502.3)	50 (127.00)	87½ (222.25)	237¼ (602.6)	2½ (6.35)	6 (15.25)	6 (15.25)	20 (50.8)	20¾ (52.7)	48 (121.92)	32 (81.28)	90 (228.60)

Specifications subject to change without notice. Consult factory to consult on other boiler options.



Bryan Steam LLC — Leaders Since 1916
 783 N. Chili Ave., Peru, Indiana 46970 U.S.A.
 Phone: 765-473-6651 • Internet: www.bryanboilers.com
 Fax: 765-473-3074 • E-mail: bryanboilers@iquest.net